

TECHNICAL CATALOGUE

A DESIGN GUIDE FOR CAR LIFT

Hydraulic Car Lift Design Details

Number of Stops:	2 up to 4
Capacity:	Up to 4500kgs, min.rated load according to available car area from table 1.1.A in EN 81-2.
Travel:	up to 10mt
Pit:	1,3 mt
HeadRoom:	3,5 mt
Machine Room:	Beside the lift shaft.
Distance between guide brackets:	2,5 up to 3,3 mt
Speed:	0,1 - 0,2 - 0,3 - 0,4 m/s
Drive:	Hydraulic direct acting lift , driven by 2 facing cylinders so that the cabin is not suspended by cables or chains.
CYLINDER:	<p>Single acting cylinders up to 3.5 m of travel.</p> <p>Two stages telescopic cylinders up to 7 m of travel; from this travel three stages telescopic cylinder would be supplied.</p> <p>Both kind of cylinders with internal cushioned stop, hydraulic device. With interconnected pipe rupture valve. Oil inlet is placed on the bottom part of cylinders.</p> <p>They are supplied fitted to the guide rails assembly.</p>
POWER UNIT:	<p>Hydraulic power unit with motor submerged in oil, screw pump (low noise), valve block with all safety measures specified in EN 81-2, serial and instruction plates included in the power unit.</p> <p>Dimensions: 500x800x950 (height) and 500x1000x1200 (height) dependig on pumps flows and oil capacity required.</p>
CONTROL:	<p>Universal simplex, using push-buttons. Control pannel by PLC (programmable logic controler) enclosed in metal cupboard. Dimensions 800x600x200.</p> <p>Automatic landing doors remain closed whilst lift-car is not in use.</p> <p>Re-levelling with doors open.</p>
Door Opening Size:	1200 - 2800 mm
Door type :	<p>a) Central open with four sliding panels.</p> <p>b) Central open with six sliding panels.</p>
Emergency Drive:	In case of supply electrical failure during the travel, allows to reach the nearest floor and to open the door with an emergency electrical source.

DESCRIPTION

Vertical transportation of cars or vehicles with the driver present, in this case the cabine will be of suitable dimensions to allow easy access to the elevator. In any case it will be suitable for installation in private garages or in those others that have little traffic.

Another use is as a goods lift suitable for passenger (hoist), available in any cabin size requested within the specified limits

Meets all the necessary requirements of Lifts Directive 95/16/EEC, design in accordance with the harmonized standard EN 81-2

POWER

230V±5%3-phase, 50/60 Hz.
 400V±5%3-phase, 50/60 Hz.
 Star-delta starting - optional, must be ordered

SHAFT

The forces on the guide rails supports are specified in the assembly instructions along with their layout. All the necessary material for assembly using brackets to the shaft wall is supplied fixing of the guide rails supports by anchorages for concrete or solid bricks. It is intended that the guide rails will be soldered to the brackets.

LIFT CAR

Consisting of easy-to-assemble modules, made of steel plates. Modules finished in baked-enamel (epoxy-polyester) paint. Standard colour: light grey; enchased texture (rough)
 Possibility of stainless steel cabin - consult us for price
 Folded plate handrails and side barriers with the same finish as the cabin.
 Steel chequered plate 4 mm thick, primer finish.
 Possibility of stainless steel chequered plate - consult us for price.
 Lighting. 2 roof light units with prismatic diffusor. 2 strip lights in each unit; installed power 80 W.
 Standard height = 2200mm, Maximun height = 2700; consult us for greater heights.

Automatic telescopic cabin doors, 4 or 6 centrally opening pannels, without inspection holes.
 VVVF control, adjustment of opening and closing speed available as well as aceleration ramps.

ELECTRIC INSTALL.

All wiring and accessories required to fit the lift-car and shaft are supplied.
 As an option the lift-car and/or shaft wiring can be supplied pre-fitted.

MOTOR POWER

The maximun power installed and the maximun nominal consumption at 400 V, depending on the load and the nominal speed, are as follows:

	2500 Kg	3000 Kg	3500 Kg	4000 Kg	4500 Kg
0,1 m/s	7,7 kW / 18A	11,0 kW / 25A	11,0 kW / 25A	11,0 kW / 25A	16,2 kW / 35A
0,2 m/s	16,2 kW / 35A	19,8 kW / 42A	19,8 kW / 42A	24,2 kW / 50A	29,4 kW / 60A
0,3 m/s	24,2 kW / 50A	24,2 kW / 50A	29,4 kW / 60A	29,4 kW / 60A	-
0,4 m/s	29,4 kW / 60A	33,0 kW / 67A	33,0 kW / 67A	-	-

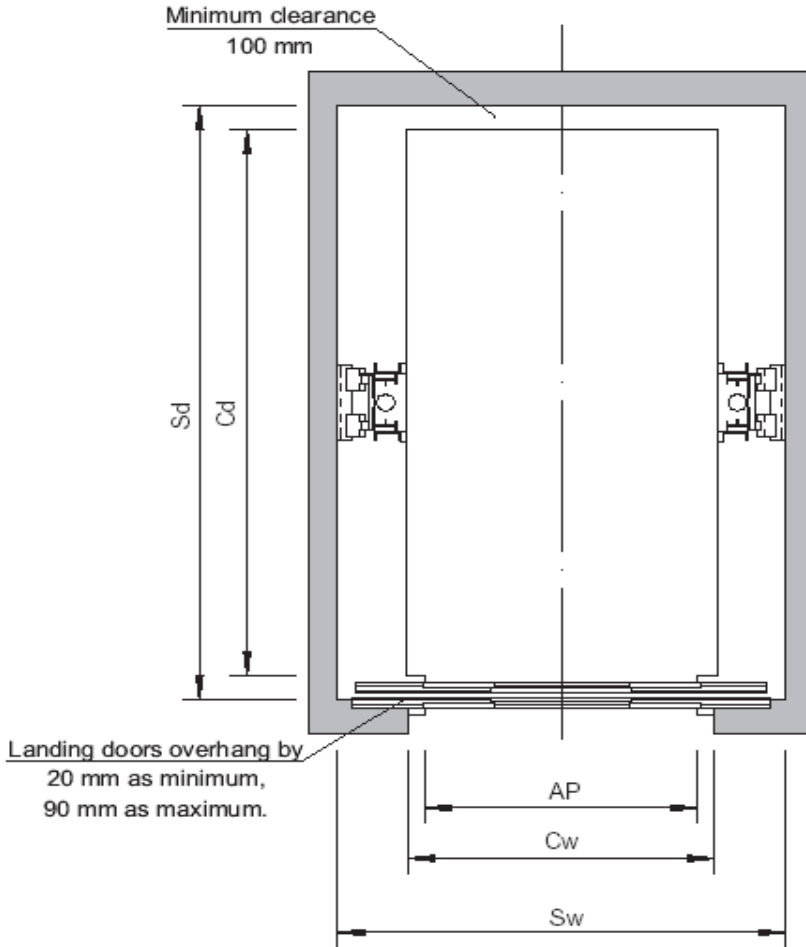

Sw = Shaft Width [mm]
Sd = Shaft Depth [mm]
Cw = Cabin Width Inside [mm]
Cd = Cabin Depth Inside [mm]
AP = Clear Door Open [mm]

$$Sd (Min) = Cd + 300$$

$$Sw (Min) = Cw + 700$$

$$Sw (Min) = 1,5AP + 150$$

Load Capacity and Max Car Surface			
		Q [kg]	S [mq]
	Area 1	2.000	6,6
	Area 2	2.500	8,6
	Area 3	3.000	10,6
	Area 4	3.500	12,6
	Area 5	4.000	14,6
	Area 6	4.500	16,6

SHAFT SIZE - MAX CABIN AND DOOR SIZE

S. Width	Shaft Depth (Sd)																										
	4000			4250			4500			4750			5000			5250			5500			5750					
	Cw	Cd	AP	Cw	Cd	AP	Cw	Cd	AP	Cw	Cd	AP	Cw	Cd	AP	Cw	Cd	AP	Cw	Cd	AP	Cw	Cd	AP	Cw	Cd	AP
2000	1300	3700	1200	1300	3950	1200	1300	4200	1200	1300	4450	1200	1300	4700	1200	1300	4950	1200	1300	5200	1200	1300	5450	1200			
2100	1400	3700	1300	1400	3950	1300	1400	4200	1300	1400	4450	1300	1400	4700	1300	1400	4950	1300	1400	5200	1300	1400	5450	1300			
2200	1500	3700	1400	1500	3950	1400	1500	4200	1400	1500	4450	1400	1500	4700	1400	1500	4950	1400	1500	5200	1400	1500	5450	1400			
2300	1600	3700	1400	1600	3950	1400	1600	4200	1400	1600	4450	1400	1600	4700	1400	1600	4950	1400	1600	5200	1400	1600	5450	1400			
2400	1700	3700	1500	1700	3950	1500	1700	4200	1500	1700	4450	1500	1700	4700	1500	1700	4950	1500	1700	5200	1500	1700	5450	1500			
2500	1800	3700	1600	1800	3950	1600	1800	4200	1600	1800	4450	1600	1800	4700	1600	1800	4950	1600	1800	5200	1600	1800	5450	1600			
2600	1900	3700	1600	1900	3950	1600	1900	4200	1600	1900	4450	1600	1900	4700	1600	1900	4950	1600	1900	5200	1600	1900	5450	1600			
2700	2000	3700	1700	2000	3950	1700	2000	4200	1700	2000	4450	1700	2000	4700	1700	2000	4950	1700	2000	5200	1700	2000	5450	1700			
2800	2100	3700	1800	2100	3950	1800	2100	4200	1800	2100	4450	1800	2100	4700	1800	2100	4950	1800	2100	5200	1800	2100	5450	1800			
2900	2200	3700	1800	2200	3950	1800	2200	4200	1800	2200	4450	1800	2200	4700	1800	2200	4950	1800	2200	5200	1800	2200	5450	1800			
3000	2300	3700	1900	2300	3950	1900	2300	4200	1900	2300	4450	1900	2300	4700	1900	2300	4950	1900	2300	5200	1900	2300	5450	1900			
3100	2400	3700	2000	2400	3950	2000	2400	4200	2000	2400	4450	2000	2400	4700	2000	2400	4950	2000	2400	5200	2000	2400	5450	2000			
3200	2500	3700	2000	2500	3950	2000	2500	4200	2000	2500	4450	2000	2500	4700	2000	2500	4950	2000	2500	5200	2000	2500	5450	2000			
3300	2600	3700	2100	2600	3950	2100	2600	4200	2100	2600	4450	2100	2600	4700	2100	2600	4950	2100	2600	5200	2100	2600	5450	2100			
3400	2700	3700	2200	2700	3950	2200	2700	4200	2200	2700	4450	2200	2700	4700	2200	2700	4950	2200	2700	5200	2200	2700	5450	2200			
3500	2800	3700	2200	2800	3950	2200	2800	4200	2200	2800	4450	2200	2800	4700	2200	2800	4950	2200	2800	5200	2200	2800	5450	2200			
3600	2900	3700	2300	2900	3950	2300	2900	4200	2300	2900	4450	2300	2900	4700	2300	2900	4950	2300	2900	5200	2300	2900	5450	2300			
3700	3000	3700	2400	3000	3950	2400	3000	4200	2400	3000	4450	2400	3000	4700	2400	3000	4950	2400	3000	5200	2400	3000	5450	2400			

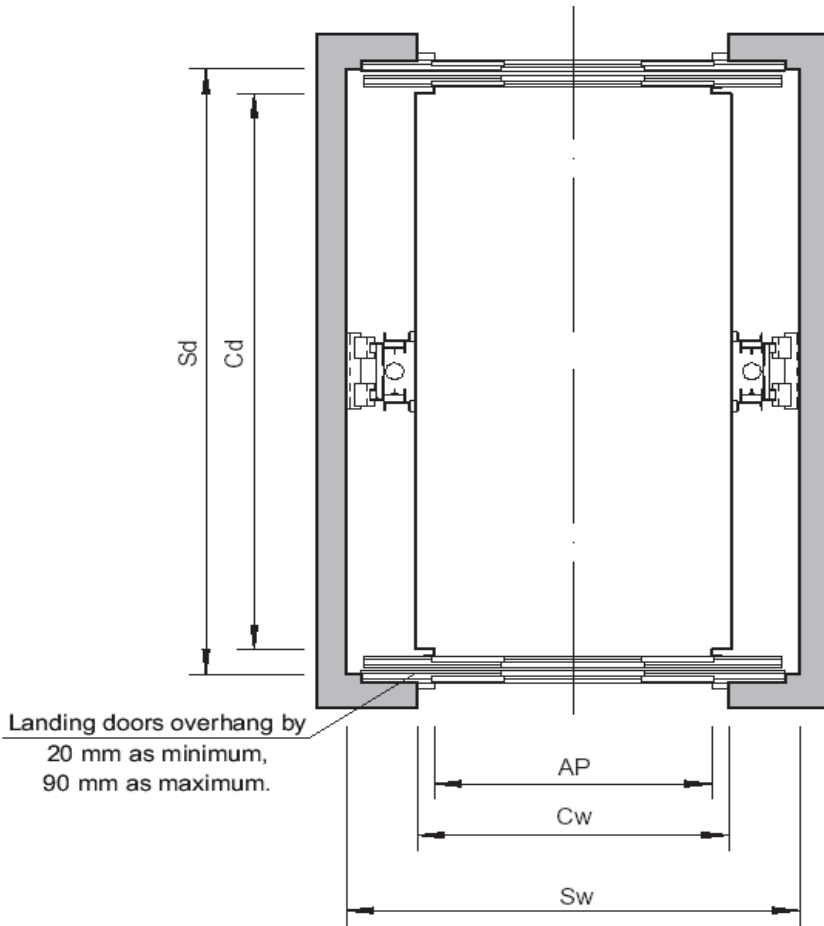

Sw = Shaft Width [mm]
 Sd = Shaft Depth [mm]
 Cw = Cabin Width Inside [mm]
 Cd = Cabin Depth Inside [mm]
 AP = Clear Door Open [mm]

$Sd (Min) = Cd + 400$
 $Sw (Min) = Cw + 700$
 $Sw (Min) = 1,5AP + 150$

Load Capacity and Max Car Surface

	Q [kg]	S [mq]
Area 1	2.000	6,6
Area 2	2.500	8,6
Area 3	3.000	10,6
Area 4	3.500	12,6
Area 5	4.000	14,6
Area 6	4.500	16,6

SHAFT SIZE - MAX CABIN AND DOOR SIZE

S. Width	Shaft Depth (Sd)																										
	4000			4250			4500			4750			5000			5250			5500			5750					
	Cw	Cd	AP	Cw	Cd	AP	Cw	Cd	AP	Cw	Cd	AP	Cw	Cd	AP	Cw	Cd	AP	Cw	Cd	AP	Cw	Cd	AP	Cw	Cd	AP
2000	1300	3600	1200	1300	3850	1200	1300	4100	1200	1300	4350	1200	1300	4600	1200	1300	4850	1200	1300	5100	1200	1300	5350	1200			
2100	1400	3600	1300	1400	3850	1300	1400	4100	1300	1400	4350	1300	1400	4600	1300	1400	4850	1300	1400	5100	1300	1400	5350	1300			
2200	1500	3600	1400	1500	3850	1400	1500	4100	1400	1500	4350	1400	1500	4600	1400	1500	4850	1400	1500	5100	1400	1500	5350	1400			
2300	1600	3600	1400	1600	3850	1400	1600	4100	1400	1600	4350	1400	1600	4600	1400	1600	4850	1400	1600	5100	1400	1600	5350	1400			
2400	1700	3600	1500	1700	3850	1500	1700	4100	1500	1700	4350	1500	1700	4600	1500	1700	4850	1500	1700	5100	1500	1700	5350	1500			
2500	1800	3600	1600	1800	3850	1600	1800	4100	1600	1800	4350	1600	1800	4600	1600	1800	4850	1600	1800	5100	1600	1800	5350	1600			
2600	1900	3600	1600	1900	3850	1600	1900	4100	1600	1900	4350	1600	1900	4600	1600	1900	4850	1600	1900	5100	1600	1900	5350	1600			
2700	2000	3600	1700	2000	3850	1700	2000	4100	1700	2000	4350	1700	2000	4600	1700	2000	4850	1700	2000	5100	1700	2000	5350	1700			
2800	2100	3600	1800	2100	3850	1800	2100	4100	1800	2100	4350	1800	2100	4600	1800	2100	4850	1800	2100	5100	1800	2100	5350	1800			
2900	2200	3600	1800	2200	3850	1800	2200	4100	1800	2200	4350	1800	2200	4600	1800	2200	4850	1800	2200	5100	1800	2200	5350	1800			
3000	2300	3600	1900	2300	3850	1900	2300	4100	1900	2300	4350	1900	2300	4600	1900	2300	4850	1900	2300	5100	1900	2300	5350	1900			
3100	2400	3600	2000	2400	3850	2000	2400	4100	2000	2400	4350	2000	2400	4600	2000	2400	4850	2000	2400	5100	2000	2400	5350	2000			
3200	2500	3600	2000	2500	3850	2000	2500	4100	2000	2500	4350	2000	2500	4600	2000	2500	4850	2000	2500	5100	2000	2500	5350	2000			
3300	2600	3600	2100	2600	3850	2100	2600	4100	2100	2600	4350	2100	2600	4600	2100	2600	4850	2100	2600	5100	2100	2600	5350	2100			
3400	2700	3600	2200	2700	3850	2200	2700	4100	2200	2700	4350	2200	2700	4600	2200	2700	4850	2200	2700	5100	2200	2700	5350	2200			
3500	2800	3600	2200	2800	3850	2200	2800	4100	2200	2800	4350	2200	2800	4600	2200	2800	4850	2200	2800	5100	2200	2800	5350	2200			
3600	2900	3600	2300	2900	3850	2300	2900	4100	2300	2900	4350	2300	2900	4600	2300	2900	4850	2300	2900	5100	2300	2900	5350	2300			
3700	3000	3600	2400	3000	3850	2400	3000	4100	2400	3000	4350	2400	3000	4600	2400	3000	4850	2400	3000	5100	2400	3000	5350	2400			

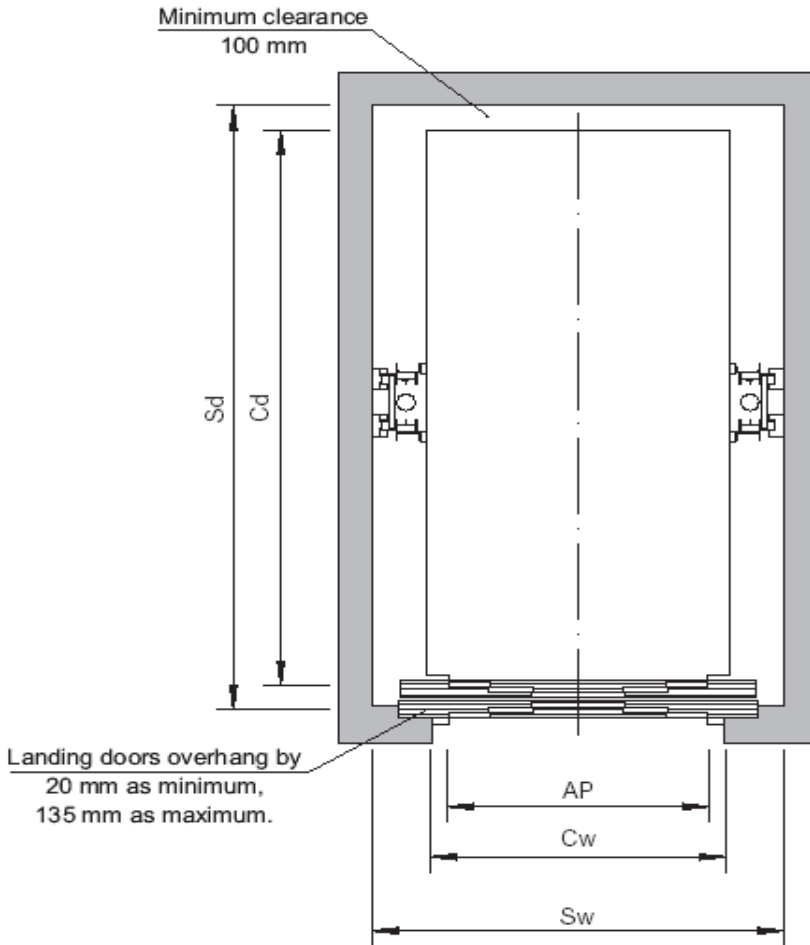

Sw = Shaft Width [mm]
 Sd = Shaft Depth [mm]
 Cw = Cabin Width Inside [mm]
 Cd = Cabin Depth Inside [mm]
 AP = Clear Door Open [mm]

$$Sd (Min) = Cd + 350$$

$$Sw (Min) = Cw + 700$$

$$Sw (Min) = 4/3AP + 150$$

Load Capacity and Max Car Surface			
		Q [kg]	S [mq]
	Area 1	2.000	6,6
	Area 2	2.500	8,6
	Area 3	3.000	10,6
	Area 4	3.500	12,6
	Area 5	4.000	14,6
	Area 6	4.500	16,6

SHAFT SIZE - MAX CABIN AND DOOR SIZE

S. Width	Shaft Depth (Sd)																										
	4000			4250			4500			4750			5000			5250			5500			5750					
	Cw	Cd	AP	Cw	Cd	AP	Cw	Cd	AP	Cw	Cd	AP	Cw	Cd	AP	Cw	Cd	AP	Cw	Cd	AP	Cw	Cd	AP	Cw	Cd	AP
2000	1300	3650	1200	1300	3900	1200	1300	4150	1200	1300	4400	1200	1300	4650	1200	1300	4900	1200	1300	5150	1200	1300	5400	1200	1300		
2100	1400	3650	1300	1400	3900	1300	1400	4150	1300	1400	4400	1300	1400	4650	1300	1400	4900	1300	1400	5150	1300	1400	5400	1300	1400		
2200	1500	3650	1400	1500	3900	1400	1500	4150	1400	1500	4400	1400	1500	4650	1400	1500	4900	1400	1500	5150	1400	1500	5400	1400	1500		
2300	1600	3650	1500	1600	3900	1500	1600	4150	1500	1600	4400	1500	1600	4650	1500	1600	4900	1500	1600	5150	1500	1600	5400	1500	1600		
2400	1700	3650	1600	1700	3900	1600	1700	4150	1600	1700	4400	1600	1700	4650	1600	1700	4900	1600	1700	5150	1600	1700	5400	1600	1700		
2500	1800	3650	1700	1800	3900	1700	1800	4150	1700	1800	4400	1700	1800	4650	1700	1800	4900	1700	1800	5150	1700	1800	5400	1700	1800		
2600	1900	3650	1800	1900	3900	1800	1900	4150	1800	1900	4400	1800	1900	4650	1800	1900	4900	1800	1900	5150	1800	1900	5400	1800	1900		
2700	2000	3650	1900	2000	3900	1900	2000	4150	1900	2000	4400	1900	2000	4650	1900	2000	4900	1900	2000	5150	1900	2000	5400	1900	2000		
2800	2100	3650	2000	2100	3900	2000	2100	4150	2000	2100	4400	2000	2100	4650	2000	2100	4900	2000	2100	5150	2000	2100	5400	2000	2100		
2900	2200	3650	2100	2200	3900	2100	2200	4150	2100	2200	4400	2100	2200	4650	2100	2200	4900	2100	2200	5150	2100	2200	5400	2100	2200		
3000	2300	3650	2200	2300	3900	2200	2300	4150	2200	2300	4400	2200	2300	4650	2200	2300	4900	2200	2300	5150	2200	2300	5400	2200	2300		
3100	2400	3650	2300	2400	3900	2300	2400	4150	2300	2400	4400	2300	2400	4650	2300	2400	4900	2300	2400	5150	2300	2400	5400	2300	2400		
3200	2500	3650	2400	2500	3900	2400	2500	4150	2400	2500	4400	2400	2500	4650	2400	2500	4900	2400	2500	5150	2400	2500	5400	2400	2500		
3300	2600	3650	2500	2600	3900	2500	2600	4150	2500	2600	4400	2500	2600	4650	2500	2600	4900	2500	2600	5150	2500	2600	5400	2500	2600		
3400	2700	3650	2600	2700	3900	2600	2700	4150	2600	2700	4400	2600	2700	4650	2600	2700	4900	2600	2700	5150	2600	2700	5400	2600	2700		
3500	2800	3650	2700	2800	3900	2700	2800	4150	2700	2800	4400	2700	2800	4650	2700	2800	4900	2700	2800	5150	2700	2800	5400	2700	2800		
3600	2900	3650	2800	2900	3900	2800	2900	4150	2800	2900	4400	2800	2900	4650	2800	2900	4900	2800	2900	5150	2800	2900	5400	2800	2900		
3700	3000	3650	2900	3000	3900	2900	3000	4150	2900	3000	4400	2900	3000	4650	2900	3000	4900	2900	3000	5150	2900	3000	5400	2900	3000		

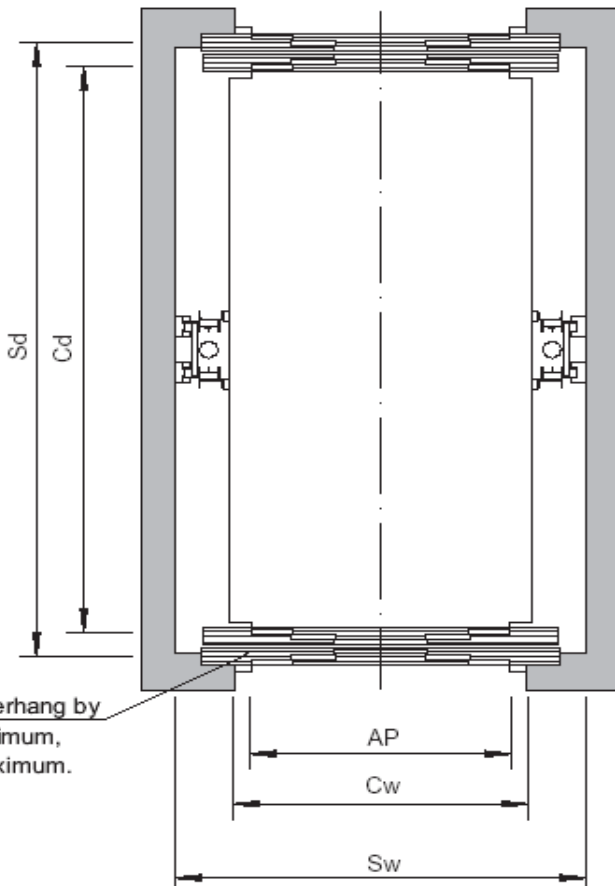

Sw = Shaft Width [mm]
 Sd = Shaft Depth [mm]
 Cw = Cabin Width Inside [mm]
 Cd = Cabin Depth Inside [mm]
 AP = Clear Door Open [mm]

$Sd (Min) = Cd + 500$
 $Sw (Min) = Cw + 700$
 $Sw (Min) = 4/3AP + 150$

Load Capacity and Max Car Surface

		Q [kg]	S [mq]
	Area 1	2.000	6,6
	Area 2	2.500	8,6
	Area 3	3.000	10,6
	Area 4	3.500	12,6
	Area 5	4.000	14,6
	Area 6	4.500	16,6

SHAFT SIZE - MAX CABIN AND DOOR SIZE

S. Width	Shaft Depth (Sd)																							
	4000			4250			4500			4750			5000			5250			5500			5750		
	Cw	Cd	AP	Cw	Cd	AP	Cw	Cd	AP	Cw	Cd	AP	Cw	Cd	AP	Cw	Cd	AP	Cw	Cd	AP	Cw	Cd	AP
2000	1300	3500	1200	1300	3750	1200	1300	4000	1200	1300	4250	1200	1300	4500	1200	1300	4750	1200	1300	5000	1200	1300	5250	1200
2100	1400	3500	1300	1400	3750	1300	1400	4000	1300	1400	4250	1300	1400	4500	1300	1400	4750	1300	1400	5000	1300	1400	5250	1300
2200	1500	3500	1400	1500	3750	1400	1500	4000	1400	1500	4250	1400	1500	4500	1400	1500	4750	1400	1500	5000	1400	1500	5250	1400
2300	1600	3500	1500	1600	3750	1500	1600	4000	1500	1600	4250	1500	1600	4500	1500	1600	4750	1500	1600	5000	1500	1600	5250	1500
2400	1700	3500	1600	1700	3750	1600	1700	4000	1600	1700	4250	1600	1700	4500	1600	1700	4750	1600	1700	5000	1600	1700	5250	1600
2500	1800	3500	1700	1800	3750	1700	1800	4000	1700	1800	4250	1700	1800	4500	1700	1800	4750	1700	1800	5000	1700	1800	5250	1700
2600	1900	3500	1800	1900	3750	1800	1900	4000	1800	1900	4250	1800	1900	4500	1800	1900	4750	1800	1900	5000	1800	1900	5250	1800
2700	2000	3500	1900	2000	3750	1900	2000	4000	1900	2000	4250	1900	2000	4500	1900	2000	4750	1900	2000	5000	1900	2000	5250	1900
2800	2100	3500	2000	2100	3750	2000	2100	4000	2000	2100	4250	2000	2100	4500	2000	2100	4750	2000	2100	5000	2000	2100	5250	2000
2900	2200	3500	2100	2200	3750	2100	2200	4000	2100	2200	4250	2100	2200	4500	2100	2200	4750	2100	2200	5000	2100	2200	5250	2100
3000	2300	3500	2200	2300	3750	2200	2300	4000	2200	2300	4250	2200	2300	4500	2200	2300	4750	2200	2300	5000	2200	2300	5250	2200
3100	2400	3500	2300	2400	3750	2300	2400	4000	2300	2400	4250	2300	2400	4500	2300	2400	4750	2300	2400	5000	2300	2400	5250	2300
3200	2500	3500	2400	2500	3750	2400	2500	4000	2400	2500	4250	2400	2500	4500	2400	2500	4750	2400	2500	5000	2400	2500	5250	2400
3300	2600	3500	2500	2600	3750	2500	2600	4000	2500	2600	4250	2500	2600	4500	2500	2600	4750	2500	2600	5000	2500	2600	5250	2500
3400	2700	3500	2600	2700	3750	2600	2700	4000	2600	2700	4250	2600	2700	4500	2600	2700	4750	2600	2700	5000	2600	2700	5250	2600
3500	2800	3500	2700	2800	3750	2700	2800	4000	2700	2800	4250	2700	2800	4500	2700	2800	4750	2700	2800	5000	2700	2800	5250	2700
3600	2900	3500	2800	2900	3750	2800	2900	4000	2800	2900	4250	2800	2900	4500	2800	2900	4750	2800	2900	5000	2800	2900	5250	2800
3700	3000	3500	2900	3000	3750	2900	3000	4000	2900	3000	4250	2900	3000	4500	2900	3000	4750	2900	3000	5000	2900	3000	5250	2900

Section view

